

VINYL BANNER FEATURES

All of our banners are manufactured to the industry's highest standards. Our vinyl banner features include the following:

- 18 oz. opaque white blackout vinyl
 - Printed at 720 dpi maximum
 - Printed using true outdoor UV resistant inks
 - Unlimited colors available
 - Photographic looks
 - Finished with scratch resistant UV clear coat, the same clear coat that is used by DOT on road signs, but formulated to allow for flexibility
 - Water, mildew and fade resistant
 - UV treated heavy duty thread to match fabric
 - UV resistant material
 - Full double rolled rod pockets constructed with our unique "one piece" design
-
- Full double rolled rod pockets constructed with our unique "one piece" integral design
 - Solid brass grommets in all four corners so that banner can be installed from either side. This also extends the life of the banner by rotating them each year
 - Durable webbing sewn in behind grommets to help prevent tearing
 - All seams have double row stitching with double lock stitching
 - Back stitching in stress areas

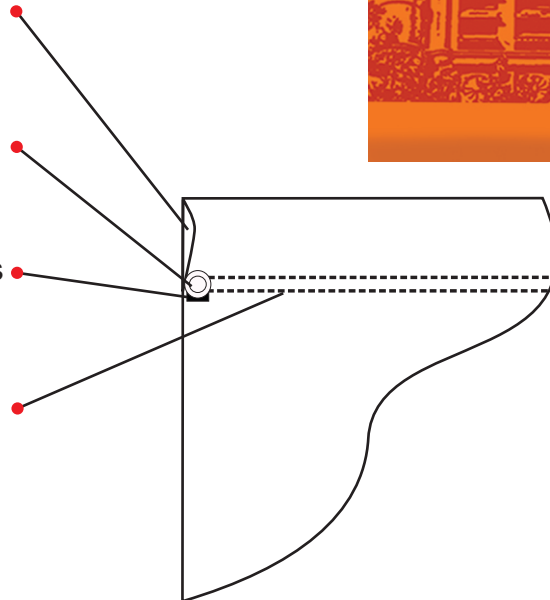

WARRANTY

Exterior banners manufactured on 18 oz. blackout vinyl in standard sizes up to 30"x 94" are **warranted for three full years**. This warranty is in effect from the date of purchase against defects in the material and craftsmanship when installed taut and reasonably maintained on Fibreflex® Brackets or approved bracketing systems. Banners are not warranted against defective or improperly installed brackets. Banners attached on hardware that allow the banner to "fly" at the bottom are not warranted after installation.